

CCDS1415-CMA Corner Adaptor Solaris Dome.

Corner Fixture (Using CCDS1415-CMA combined with CCDS1415-WM)

The bracket is supplied in two parts.

Using 3 x M8 Nuts and M8 x 20 Bolts fasten the two brackets as shown below.

Fasten the corner bracket to the mounting substrate using the eight holes shown.

Note: Ensure the chosen fasteners and fastening method are suitable for the application and the mounting substrate. For CCTV installations only.

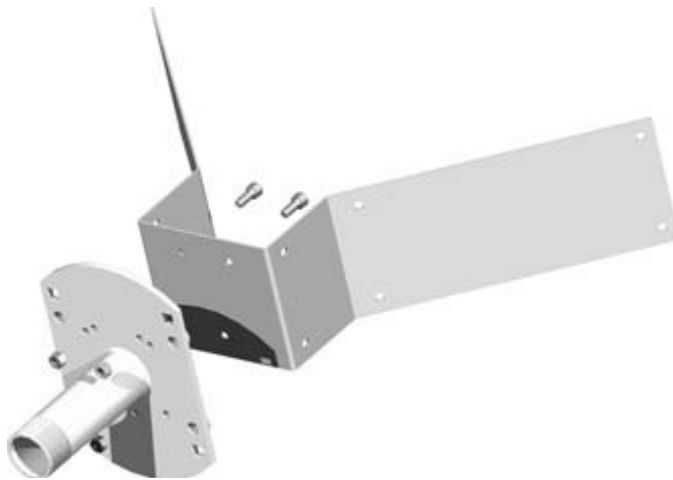

The SOLARIS dome should be installed by competent, qualified personnel in accordance with the latest national standards.

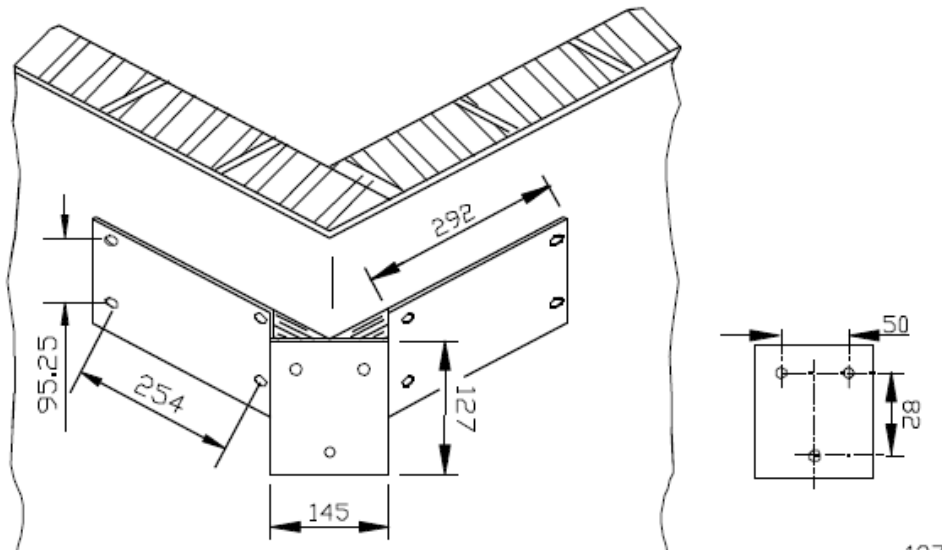

Construction Material: 10 SWG mild steel

Screws, nuts etc: Stainless steel

Colour: White

Williams Electronics Limited trading as MOLYNX Systems.

Williams Electronics Ltd

9 - 10 Wernddu Court,

Caerphilly Business Park,

Caerphilly

CF83 3ED